

Gepäckbrücke  
BMW F 800 ST

Artikel-Nr.:  
650.647 01 09 silber

Seitenkoffer  
Topcases  
Gepäckträger  
Lock it System  
Softbags  
Aluminiumkoffer  
Lederkoffer  
Schutzbügel  
Hauptständer  
Chopper-Parts  
Quad-Parts  
Accessoires



## Montage

Stück quant	Bestellnr. item no.	Bezeichnung description
1	705.114HB	Gepäckbrücke rear carrier
1	705.218HB	Gegenhaltetasche shackle
1	270.109	Moosgummistreifen ca. 14 cm rubber buffer
2	150.729	Linsenkopfschrauben M 8 x 55 fillister headscrew
2	151.038	Linsenkopfschrauben M 6 x 40 fillister headscrew
2	150.810	U-Scheiben ø8,4 washer
4	150.809	U-Scheiben ø6,4 washer
2	150.799	selbstsichernde Muttern M 6 self-lock nut



**Nach der Montage alle Verschraubungen auf festen Sitz kontrollieren!**  
**Control all screw connections after the assembly for tightness!**

**Bitte beachten Sie unsere beigegefügte Serviceinformationen.**  
**Please notice our enclosed service information.**

Weiteres Zubehör:  
Kofferträger, abnehmbar,

Art.-Nr. 650.647. 00 01 in schwarz -als Ergänzung montierbar



**Hepco & Becker GmbH**  
**An der Steinmauer 6**

**D-66955 Pirmasens**

**Tel.: 06331 - 1453 - 100**  
**Fax: 06331 - 1453 - 120**  
**eMail: [vertrieb@hepco-becker.de](mailto:vertrieb@hepco-becker.de)**  
**[www.hepco-becker.de](http://www.hepco-becker.de)**

Gepäckbrücke  
BMW F 800 ST

Artikel-Nr.:  
650.647 01 09 silber

Seitenkoffer  
Topcases  
Gepäckträger  
Lock it System  
Softbags  
Aluminiumkoffer  
Lederkoffer  
Schutzbügel  
Hauptständer  
Chopper-Parts  
Quad-Parts  
Accessoires



## Montage

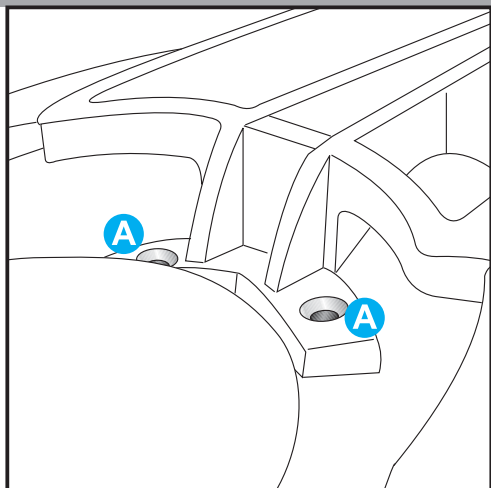

1

Vorbereitende Arbeiten:

Die hinteren Blinker und die Original-Gepäckpalette verbleiben in der Originalposition. Die beiden hinteren Befestigungsschrauben **A** der Gepäckpalette demontieren. Den mitgelieferten Moosgummistreifen auf der hinteren Querverbindung der Brücke von unten aufkleben:

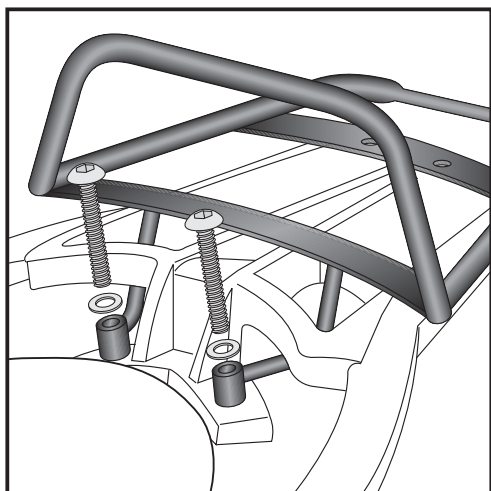
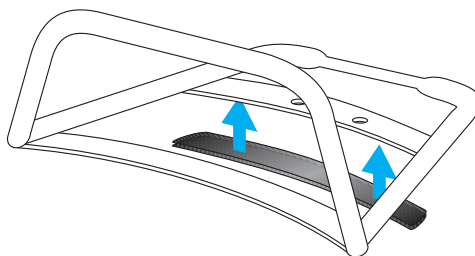

2

Befestigung der Gepäckbrücke vorne:

Die Hülsen der Gepäckbrücke werden an den hinteren Verschraubungspunkten der Original-Gepäckpalette mit den Linsenkopfschrauben M 8 x 55 nebst U-Scheiben  $\varnothing 8,4$  verschraubt.

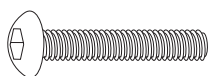

je 2x

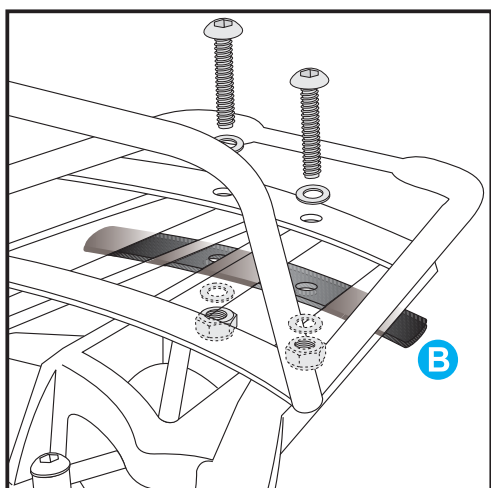

3

Befestigung der Gepäckbrücke hinten:

Die Verschraubung erfolgt mit den Linsenkopfschrauben M 6 x 40 nebst U-Scheiben  $\varnothing 6,4$ , sowie selbstsichernden Muttern M 6 und der Gegenhaltetasche **B** von unten.

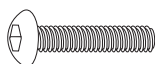

je 2x



4x



Rear carrier  
BMW F 800 ST

Item - No.:  
650.647 01 09 silver

Assembling instructions

Side cases  
Top cases  
luggage frames  
Lock it system  
Softbags  
Aluminium luggage  
Leather luggage  
Protection bars  
Center stands  
Chopper parts  
Quad parts  
Accessories



The kit includes the following parts:  
quant item no. description

1	705.114HB	rear carrier
1	705.218HB	shackle
1	270.109	rubber buffer ca. 14 cm
2	150.729	fillister headscrew M 8 x 55
2	151.038	fillister headscrew M 6 x 40
2	150.810	washer ø8,4
4	150.809	washer ø6,4
2	150.799	self-lock nut M 6



**Control all screw connections after the assembling for tightness!**  
**Please notice our enclosed service information.**

Also available:

Item-no.: 650.647 00 01

Side carrier, Lock it-System (demountable), black



**Hepco & Becker GmbH**  
**An der Steinmauer 6**  
**D-66955 Pirmasens**  
**Germany**

**Tel.: +49 6331 - 1453 - 100**  
**Fax: +49 6331 - 1453 - 120**  
**eMail: [vertrieb@hepco-becker.de](mailto:vertrieb@hepco-becker.de)**  
**[www.hepco-becker.de](http://www.hepco-becker.de)**

Rear carrier  
BMW F 800 ST

Item - No.:  
650.647 01 09 silver

Side cases  
Top cases  
luggage frames  
Lock it system  
Softbags  
Aluminium luggage  
Leather luggage  
Protection bars  
Center stands  
Chopper parts  
Quad parts  
Accessories



## Assembling instructions

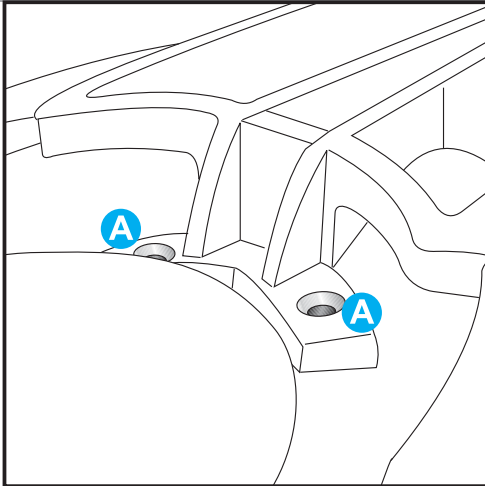

1

### Preparing:

The rear winker and the original-rear rack remains in original position. Unmount the two rear screws **A** from the original-rear rack.

Glue on the rubber buffer to the Hepco & Becker rear rack as shown:

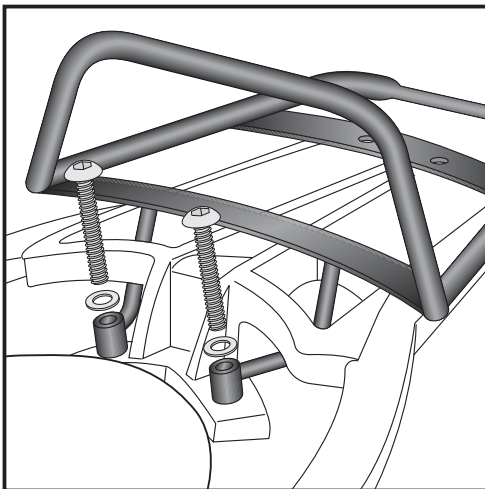
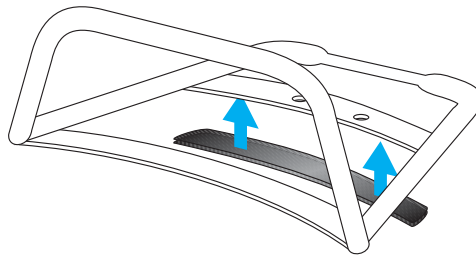

2

### Fastening of the rear rack front:

At the original rear fixing points with filister head screw M 8 x 55 and washer  $\varnothing 8,4$ .

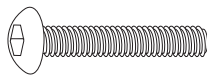

each 2x

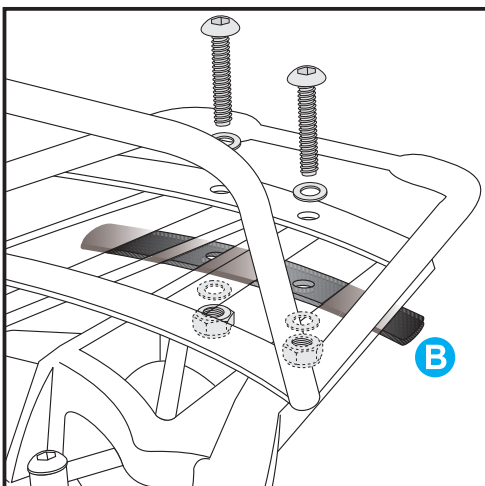

3

### Fastening of the rear rack back:

Use filister head screw M 6 x 40 and washer  $\varnothing 6,4$ .

From the bottom sandwich the shackle **B** and fix it with washer  $\varnothing 6,4$  and self-lock nut M 6.

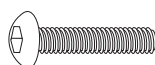

each 2x



4x

